



THE PAKS NPP SUBSEQUENT LICENCE RENEWAL PROGRAMME AND ITS CHALLENGES

Nuclear Innovation Conference – NIC2026
June 10-11, Haarlem, Netherland

Mihály Czibula
SLR Program Manager
Paks Nuclear Power Plant

MVM Paks NPP

PAKS NUCLEAR POWER PLANT

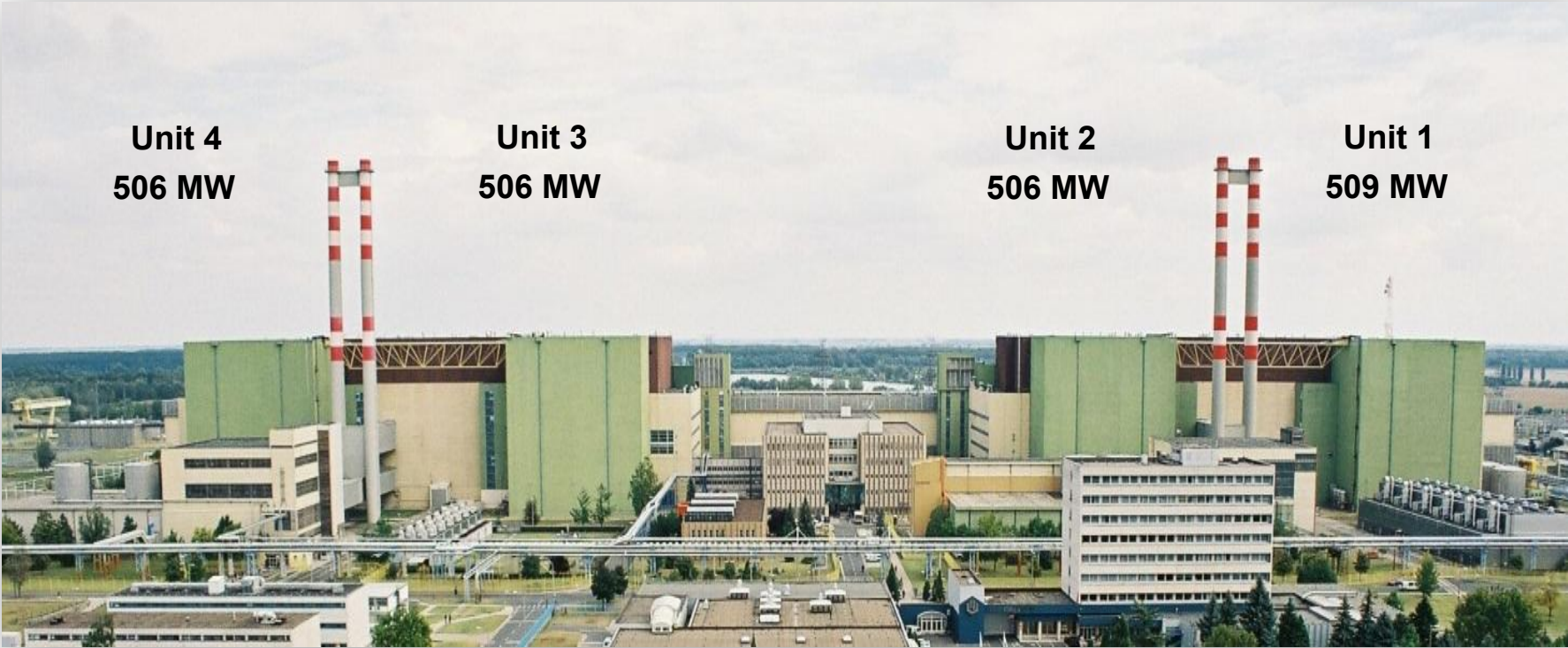

Electricity consumption 2025

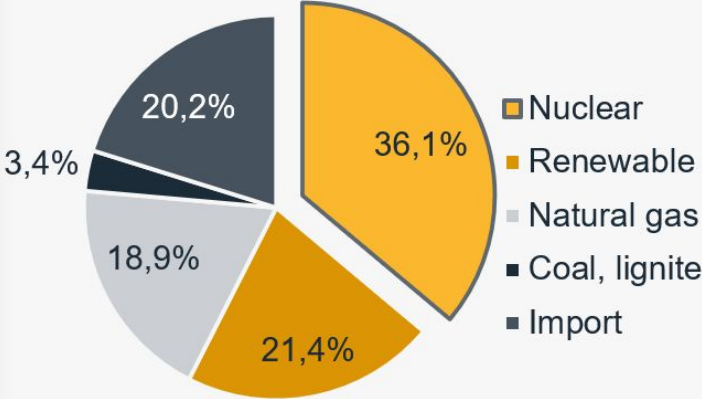

	Start up of the unit	Power up-rate	30-year life time	50-year life time	70-year life time
Unit 1	1982	2007	2012	2032 - licensed	2052 – to be licensed
Unit 2	1984	2008	2014	2034 - licensed	2054 – to be licensed
Unit 3	1986	2009	2016	2036 - licensed	2056 – to be licensed
Unit 4	1987	2006	2017	2037 - licensed	2057 – to be licensed

SLR LICENSES IN HUNGARY

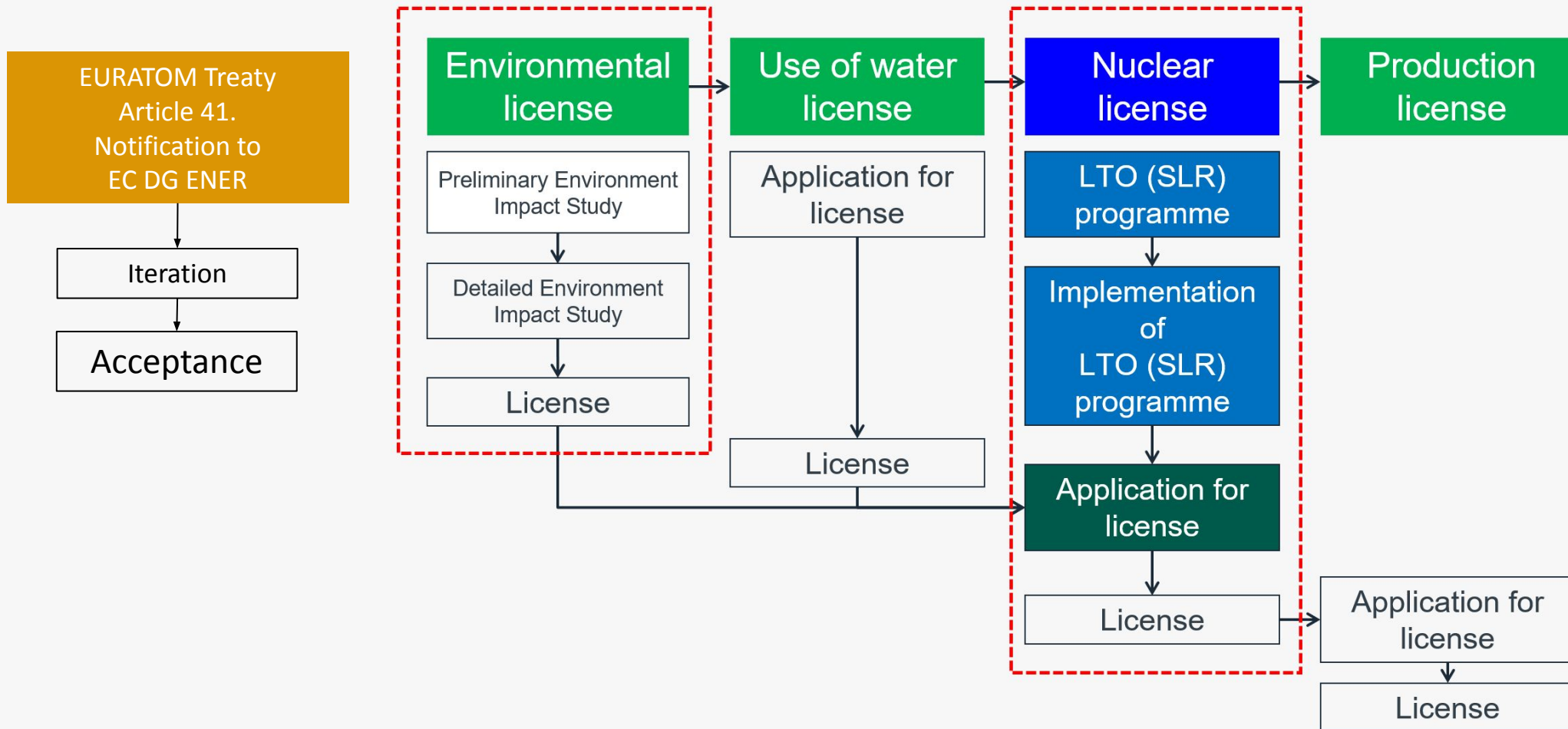

- Steering Committee: Secretary of the State, President of the HAEA, Owner CNO, Paks NPP CEO, Paks 2 CEO, PURAM CEO
- 2023 Q3: Notification to European Commission DG ENER according to the Euratom Treaty Article 41. Iteration is in progress.
- 2 minor licensing (Use of Water, Production) are needed
- Nuclear licensing divided into 2 phases: LTO Programme for 1-4 Units in one 2028 Q4, SLR application request for each Units: Unit 1: 2031 Q4, Unit 3: 2033 Q4, Unit 3: 2035 Q4, Unit 1: 2036 Q4
- Environmental Licensing is divided into 2 phases: Preliminary Consultation and Impact Assessment Phase

ENVIRONMENTAL LICENSING

Environmental Impact Programme Scope

1. Characterization of the site (inc. seismic risk)
2. Weather conditions
3. Presentation and assessment of the subsurface water environment
4. Hydrological characterization of the site
5. **Condition of the Danube and other surface water – Global Warming**
6. General characterization of the site radioactivity environment
7. Assessment of noise
8. Assessment of air quality
9. Characterization of the wildlife's exposure to radiation (expect human exposure)
10. Performing samples for biomonitoring investigations
11. Assessment of the population's exposure to radiation
12. Assessment of the population health in the vicinity of the site
13. Analyzing potential transboundary environmental impacts



STATUS:

- Preliminary Consultation Phase ended in October 2024. 49 taking notes arrived (eg. Light pollution assessment is needed). Austria, Czechia, Croatia, Romania, Latvia want to be involved; Finland, Poland have to be informed.
- All the 13 programs and the Environmental Impact Assessment are done, independent review (Environmental Expert Board) is in progress.
- Licence application request will be submitted on June 30, 2026.
- International and domestic public hearings: 2026 Q4 - 2027 Q2

NUCLEAR LICENSING

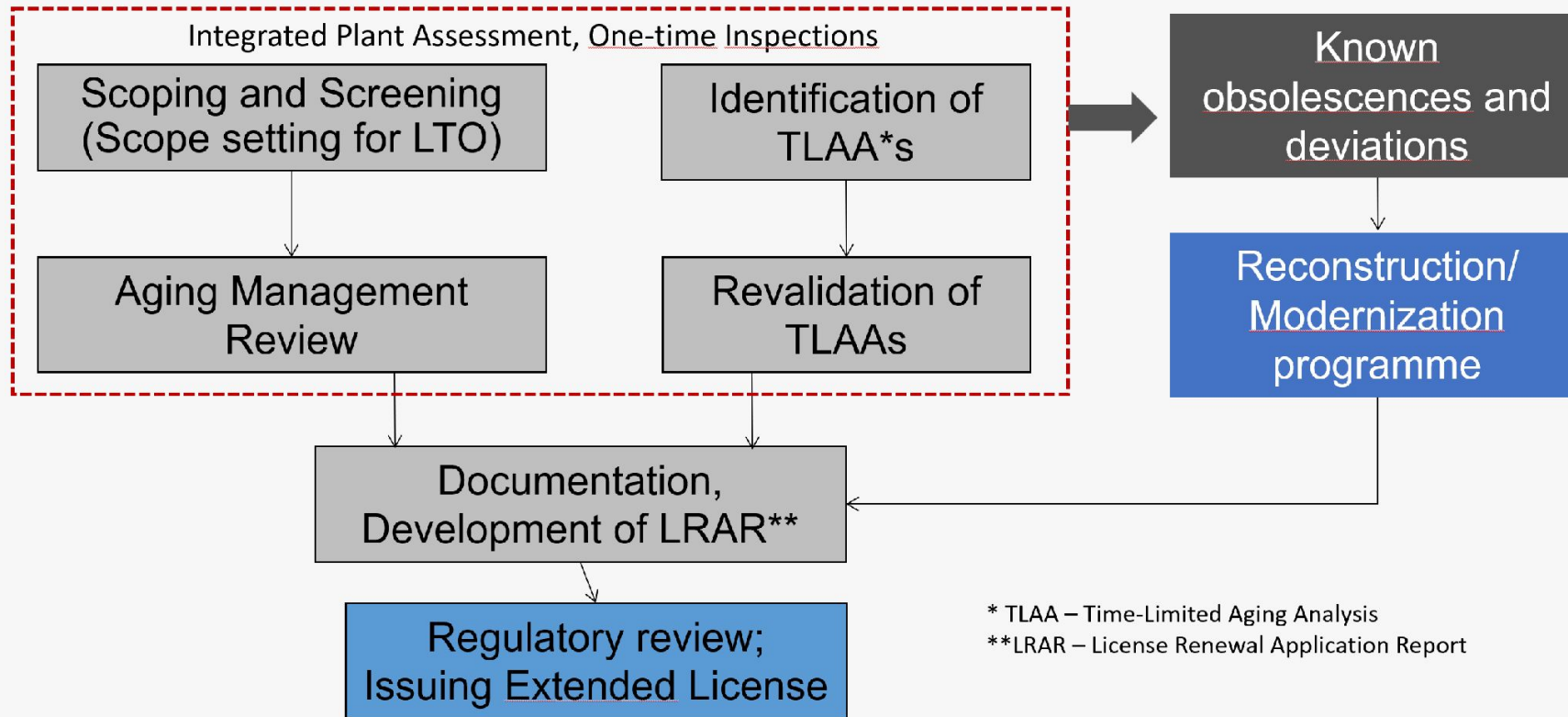

* TLAA – Time-Limited Aging Analysis
 **LRAR – License Renewal Application Report

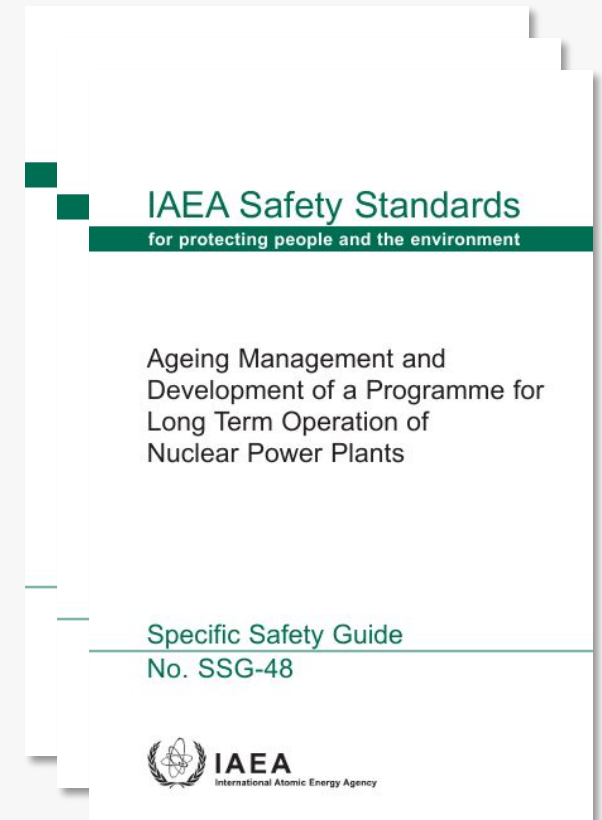

- The method is the Adaptation of US NRC practices - 10CFR54 and 10CFR50.65
- Hungarian licensing follows the IAEA guidelines, IGALL
- On the basis of ASME BPVC Section III, XI and O&M version 2017 – the ASME code was adapted in Hungary in 2011
- IAEA supports the Paks NPP Nuclear Licensing, extrabudgetary programme was defined in 2023, workshops, expert missions, independent reviews are in progress
- IAEA pre-SALTO mission will be organized in May 2028, SALTO 2031, SALTO follow-up 2033 (according to IAEA-SVS-26).

- Inspections of the core barrel baffle bolting in units 1-4; replacement/repair if necessary;
- Reconstruction of fuel handling pool and spent fuel pool liner and the underlying carbon steel and concrete components in units 1-4;
- Replacement of cables not complying with the equipment's environmental qualification – **9,5 month outage/unit**;
- Replacement of diesel generators for Units 1 and 2;
- Replacement/refurbishment of main generators
- Replacement of obsolete pressure and pressure difference gauge transmitters;
- Replacement and lowering of the Essential Service Water Pumps
- Main Control Room and Emergency Control Room panel and board devices, equipment replacement;
- Control and Protection System control rod drive mechanism (CRDM) replacement;
- Reactor protection systems radiation detectors, amplifiers, interface modules replacement;

Cost estimation

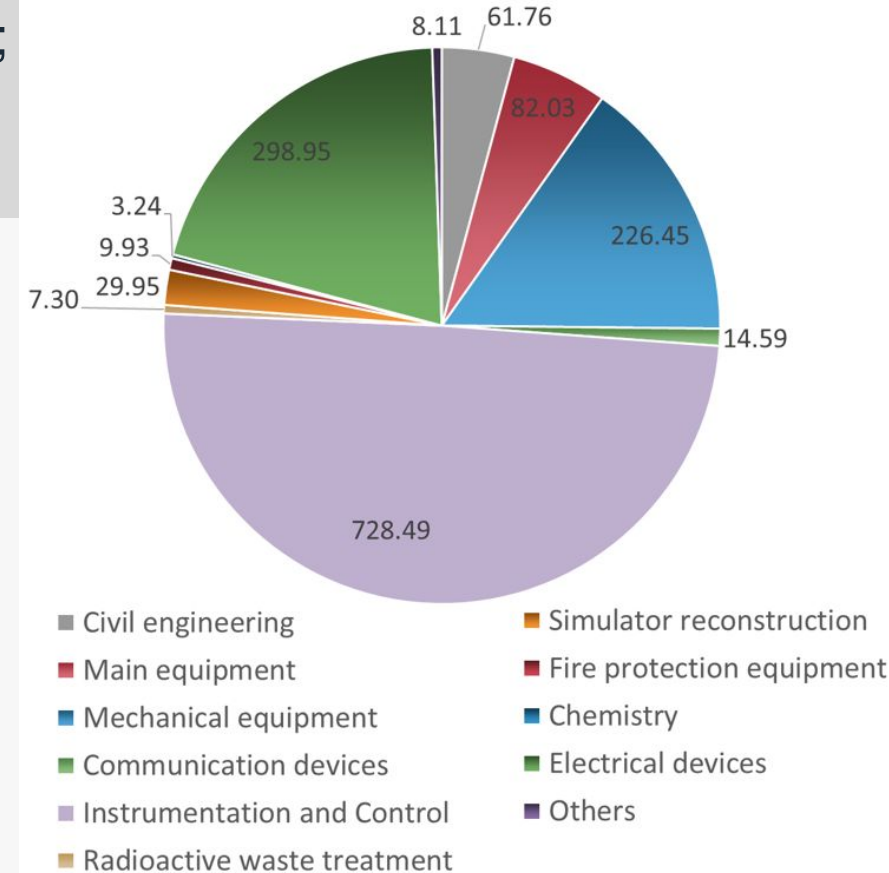

MITIGATION OF THERMAL LOAD ON THE DANUBE

Recommended Main Solution

Construction of an alternative hot water outlet channel with a new southern inlet point and sluice gating, sizing of a modular cooling cell system over 500 m ensuring 30 °C, thereby avoiding the curtailment of the Paks Nuclear Power Plant in case of high Danube water temperatures, ensuring the uninterrupted operation of the units.

Justification

Best in the compliance–time–cost–risk space; faster to implement; independent of Paks 2 NPP (new buildt); good return on investment; adjustable in operation.

The modular cooling cell system sized for a 33 °C discharge target offers the best compromise (compliance safety × rapid implementation × manageable CAPEX × scalability).

Disadvantage

Natura 2000 licensing, noise protection, and the creation of a new refuge area.

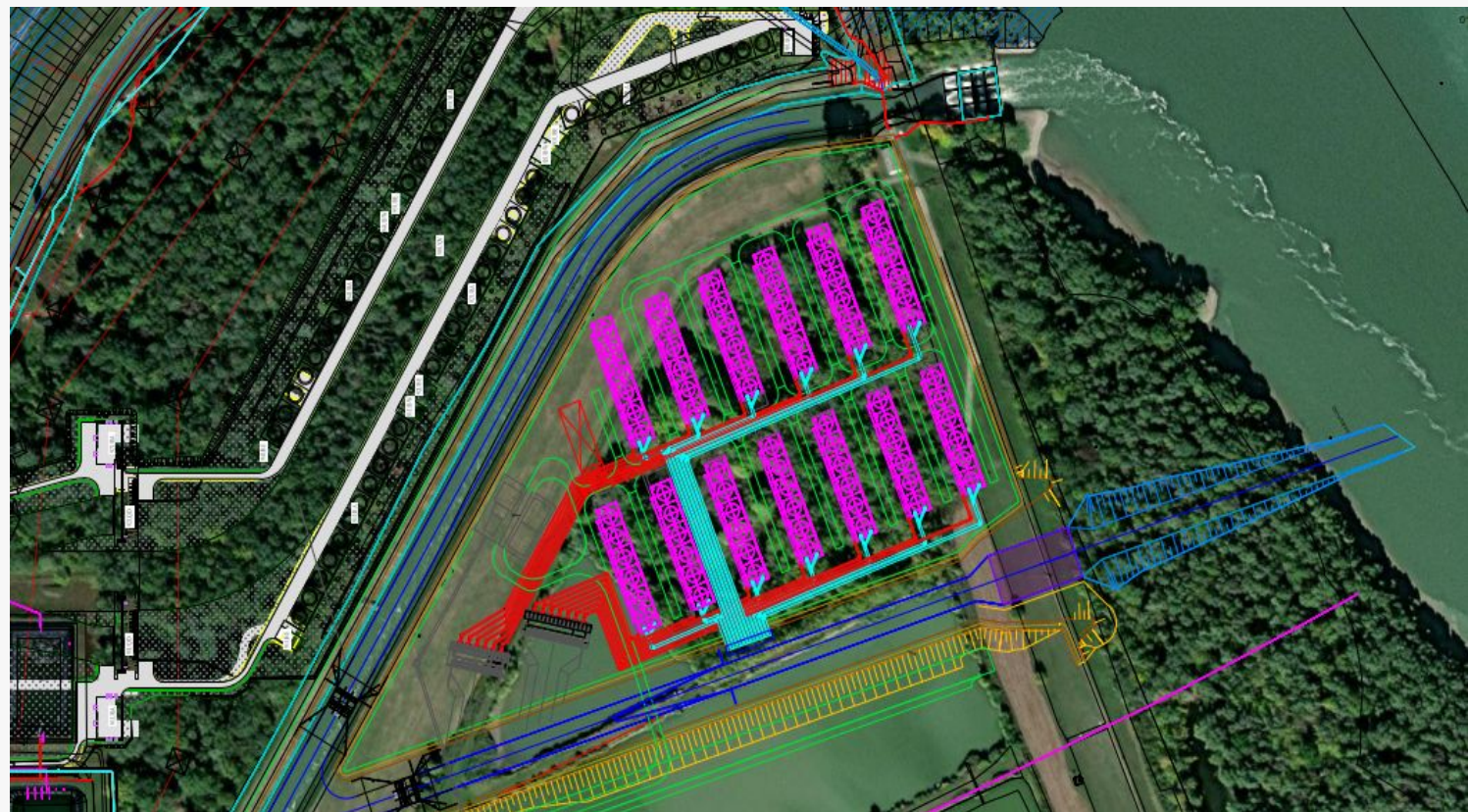

Technical specification

- Cooling capacity: 2108 MW;
- Electrical energy demand (operation): 31.37 MW;
- Number of cooling cells: 51 pcs

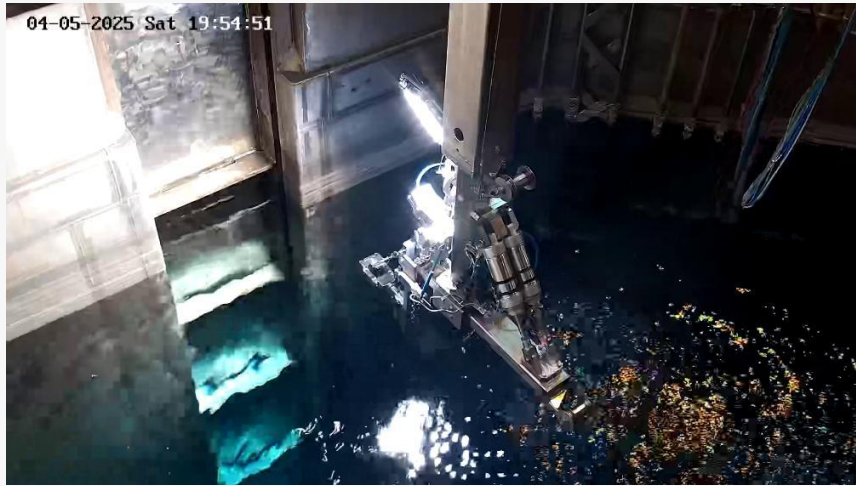

- Fact: SFP coolant loss => leakage
- 265 known liner cladding defect locations – repairs are in progress on 1-4 Units, in 2025: 55 repairs
- Liner cladding, concrete inspections - continuous program
- Concrete sampling, structure strength testing: adequate strength
- Pressure test, UT, VT, Vacuum Inspection of SFP cooling circuit piping
- Coating inspection of the SFP: UT, VT and ET NDE methods
- Metallic and non-metallic repair techniques
- Seeking solutions in international cooperation: EPRI, CEZ on the basis of the EDF good practices - Megapol

CABLE REPLACEMENT

- Taking into consideration the condition of the cable samples, it has been decided that the environmental qualification of cables inside the containment will not be performed.
- Cable replacement => 50 km/unit
- A dedicated project was established for the implementation of the cable replacement, including the junction boxes and hermetic penetrations
- Preparation of the technical design is in progress
- Compliance of cable trays is questionable – may additional scope
- 9.5-month major outages, approx. 750.000 EUR revenue loss – lost generation
- 4 heavily loss-making years
- Massive work management tasks, taking into consideration the other tasks in the same workwindow
- Configuration information risks
- Waste management challenges



INTERIM STORAGE OF LTO SURPLUS SPENT FUEL



Present MVDS



Future HOLTEC HI-STORM UMAX

- Expansion of the Modular Vault Dry Storage - ISFSF with an alternative storage solution – HOLTEC HI-STORM UMAX
- The central element of the technical solution is a stainless steel Multi-Purpose Canister (MPC), which is capable of accommodating 85 fuel assemblies.

Advantages of Containerized Storage vs. MVDS:

- Capable of storing non-hermetic fuel assemblies
- Fast construction, deployability
- Flexible expandable, containers can be shipped out continuously (e.g., in case of reprocessing)
- 10% lower investment cost
- Simpler, cheaper operation
- Can be expanded with smaller investments (container by container)
- Proven technology, much more widely used than MVDS
- Its deployment and storage also mean a lower environmental impact
- Decommissioning is simpler and cheaper
- Better protection against earthquakes and aircraft crashes
- Passive cooling, low operational risk
- Can store Paks 2 spent fuel as well – [Connecting Nuclear](#)

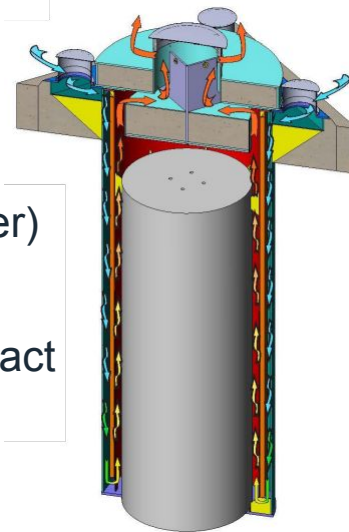

PAKS SUBSEQUENT LICENCE RENEWAL PROGRAMME TIMELINE

PURAM

PAKS NPP

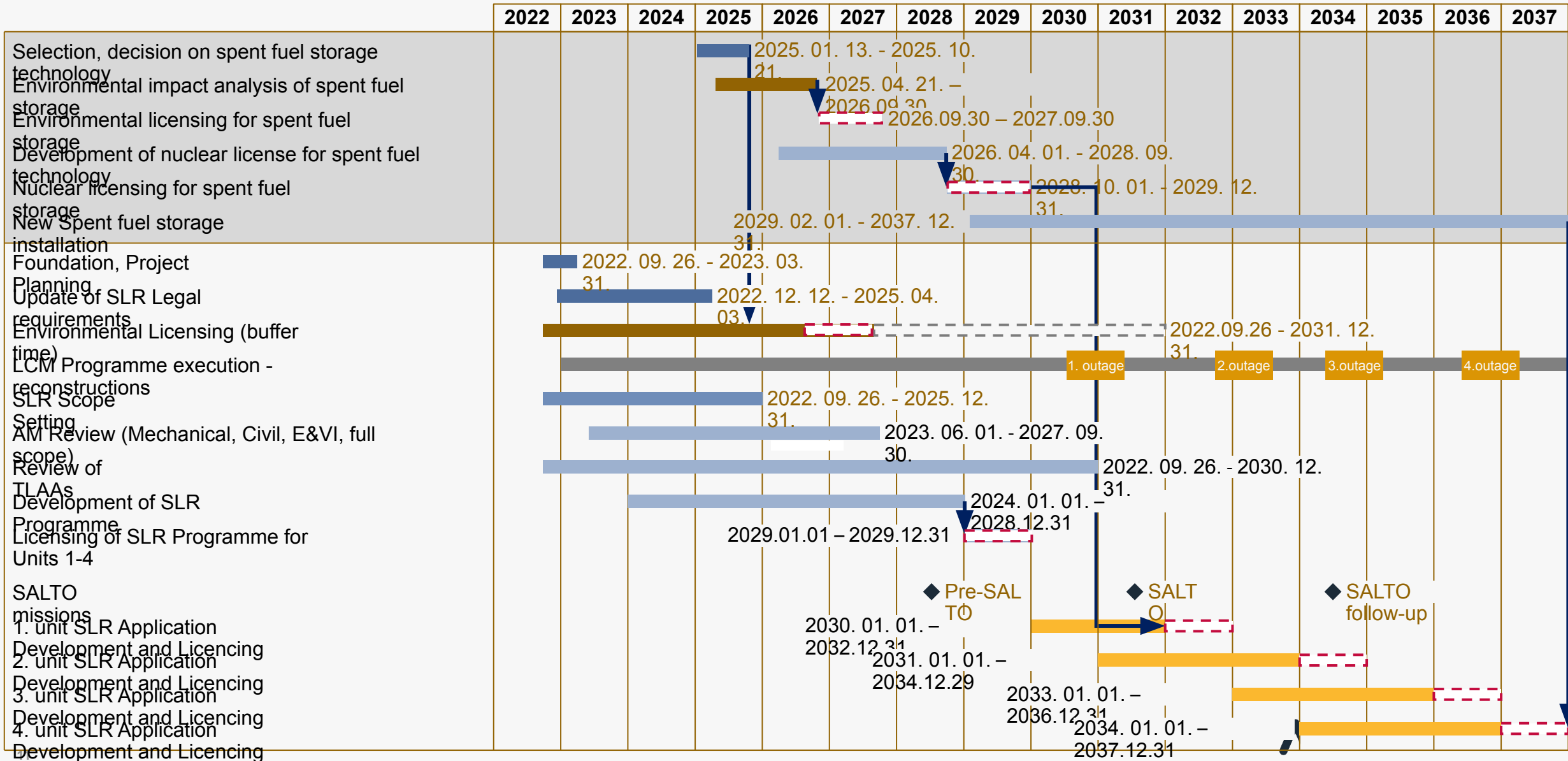

THE LCOE* VALUE OF THE SLR IS THE LOWEST AMONG THE INVESTMENT OPPORTUNITIES EXAMINED

Levelized Cost Of Energy (LCOE) by Technology Type and for the operational time extension



	Operational time extension	New nuclear power plant	New CCGT power plant	New lignite power plant	New solar power plant	New wind power plant
CAPEX (EUR/MW)	695 689	8 000 000	800 000	2 000 000	1 000 000	1 200 000
Annual availability (%)	90%	90%	80%	70%	15%	25%
Lifetime (years)	20	50	20	25	20	20
OPEX (EUR/MWh)	17	25	15	40	25	30
Efficiency (%)			55%	35%		
Fuel cost (EUR/MWh)	17	15	145	29		
CO ₂ allowance price for years (EUR/MWh)			70	70		
Balancing energy fee (EUR/MWh)					5	5



*Levelized Cost Of Energy, LCOE: Unit Energy Cost Over Life

PUBLIC ACCEPTANCE OF THE NPP OPERATION IN HUNGARY

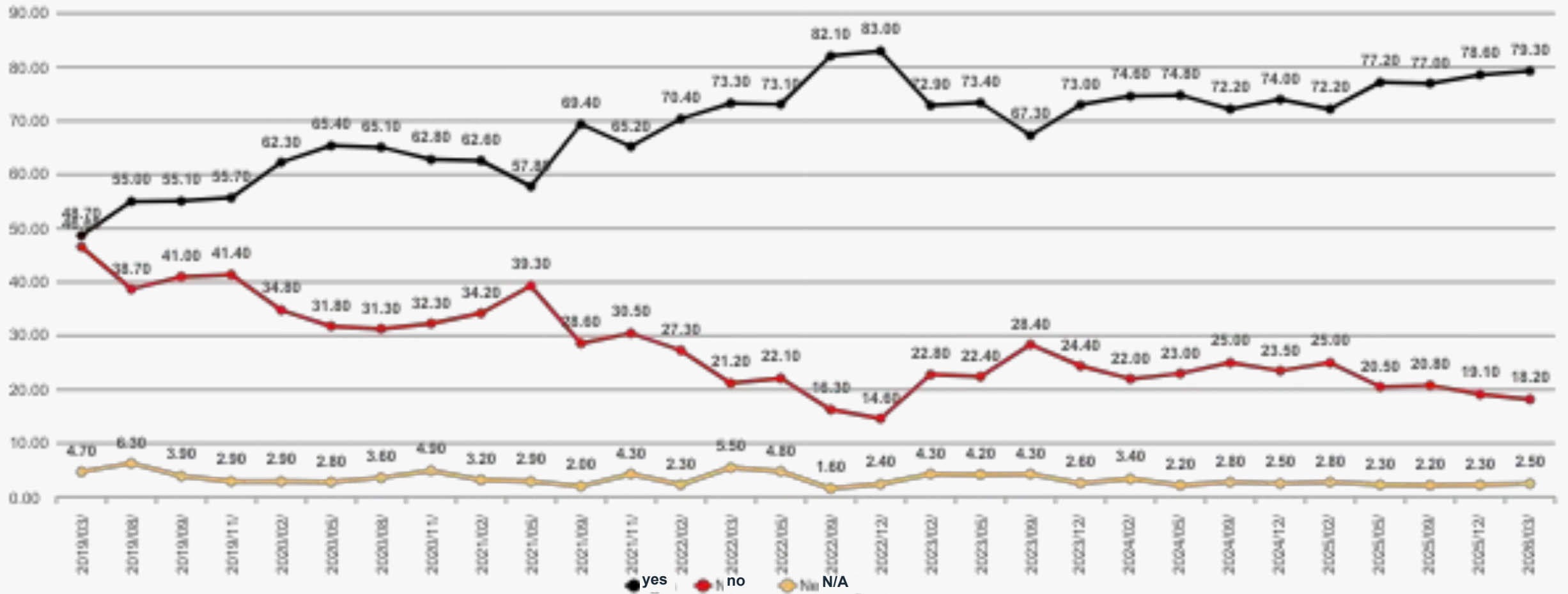

**THANK YOU FOR YOUR
ATTENTION**

